

# interact

Design

## Architecture PRF/PRA

Version v2.6

17 June 2024

# Contents

---

1. Design a parking project .....	1
1.1. Plan the lights and Wireless Gateways .....	1
1.2. Guidelines for external battery powered motion sensor .....	13
1.3. System configuration .....	19
1.4. Light behavior .....	19
2. Design a trunking project .....	20
3. Types of DALI Luminaires .....	21
3.1. DALI Version 1 .....	21
3.2. DALI version 2 .....	21
3.3. DALI 2 + D4i .....	21
3.4. SR Drivers .....	22
3.5. Architecture options .....	22
3.6. Dali Extender (Recommended Choice if available) .....	22
3.7. SR Bridge DALI (Recommended choice only when DALI extender is not possible) .....	23
3.8. SR Bridge 0-10V .....	24
3.9. SR drivers or D4i drivers directly connected to the SR sensor or antenna .....	25
3.10. Recommendation table for trunking applications .....	27

# 1. Design a parking project

This topic is intended to support the specification and design of parking project with PRF/PRA.



## Important

Before designing a parking project with PRF/PRA, see the System overview to better understand the concepts used and how it works.

To design a parking project with PRF/PRA, use the following steps:

- Plan the location of the lights and Wireless Gateways (only applicable for Advanced and Enterprise tiers)
- Define the routes of traffic cars and individuals
- Define the lighting groups and/or groups
- Plan the sensor placement for each group and/or group

## 1.1. Plan the lights and Wireless Gateways

Luminaires and sensors must be placed at the correct position, to enable the communication with other luminaires. Use the following guidelines when planning the amount of lights and Wireless Gateways:

### **Maximum number of components**

See the maximum number of components for:

- PRF/PRA system properties and limitations

### **Distance between luminaires**

- The maximum distance in a corridor (D1) is 5 m (16.4 ft).  
The maximum distance to the next luminaire (D2) is 10 m (32.8 ft), offering an extra communication possibility.

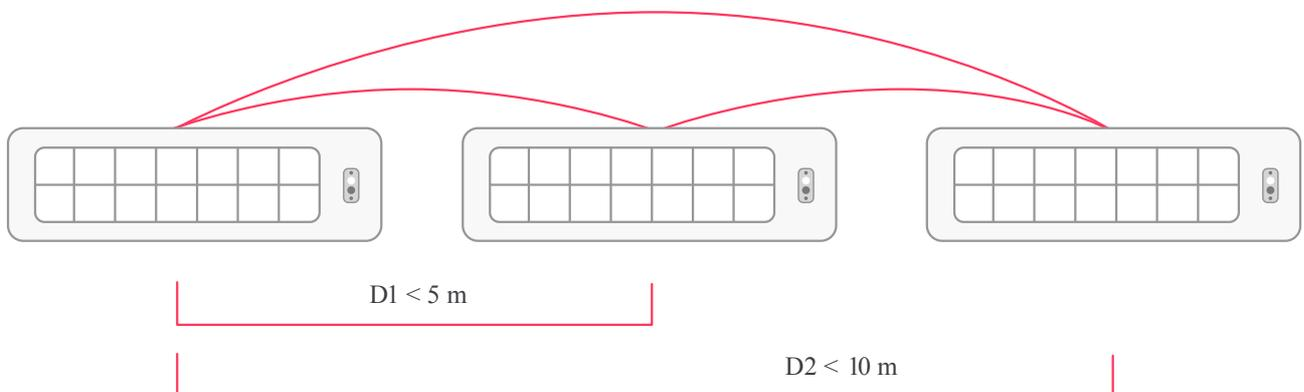

- The maximum between luminaires in an open plan is 10 m (32.8 ft)

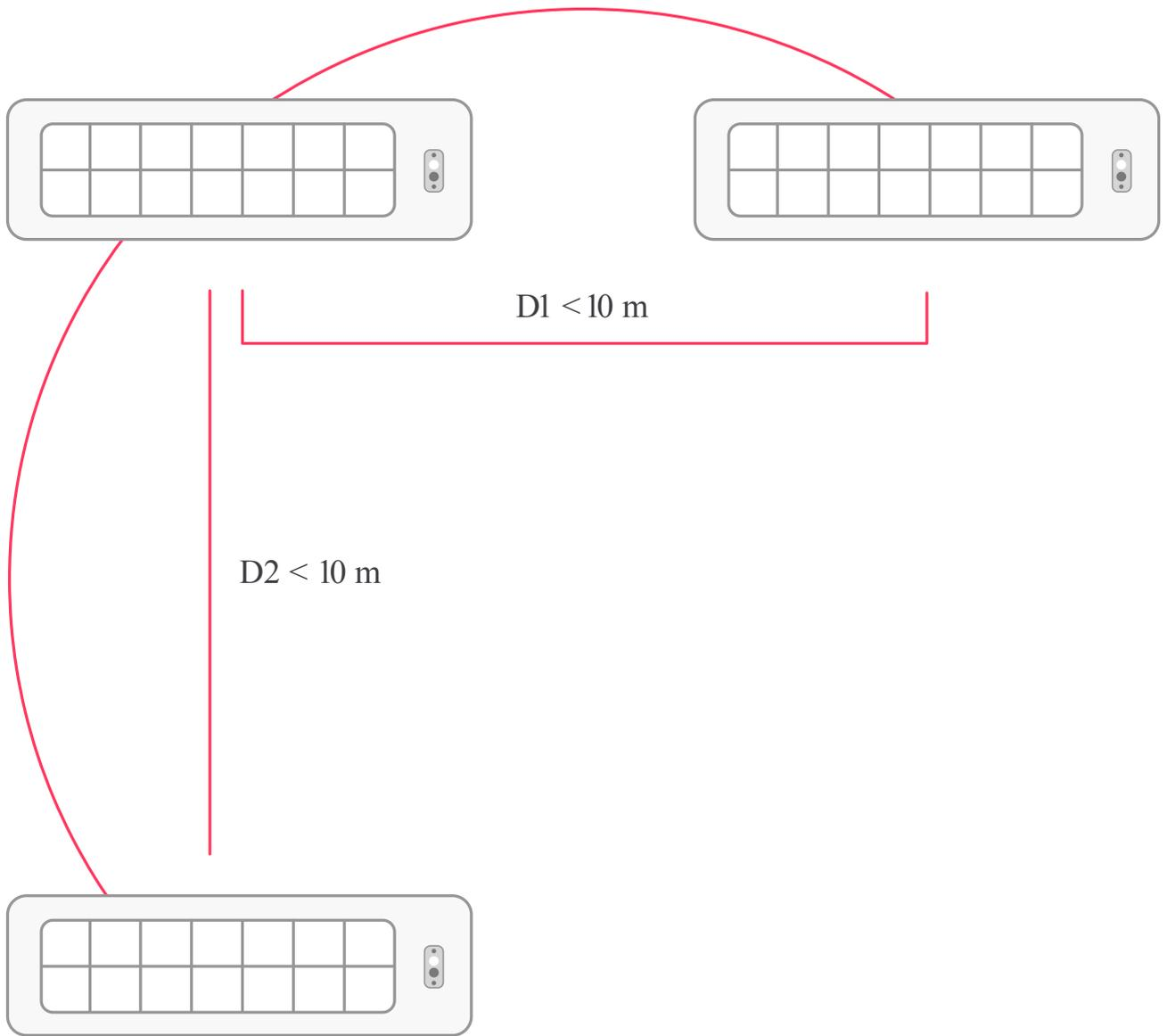

***Distance to the wall***

The minimum distance of a luminaire from the wall is 0.3 m (0.98 ft)

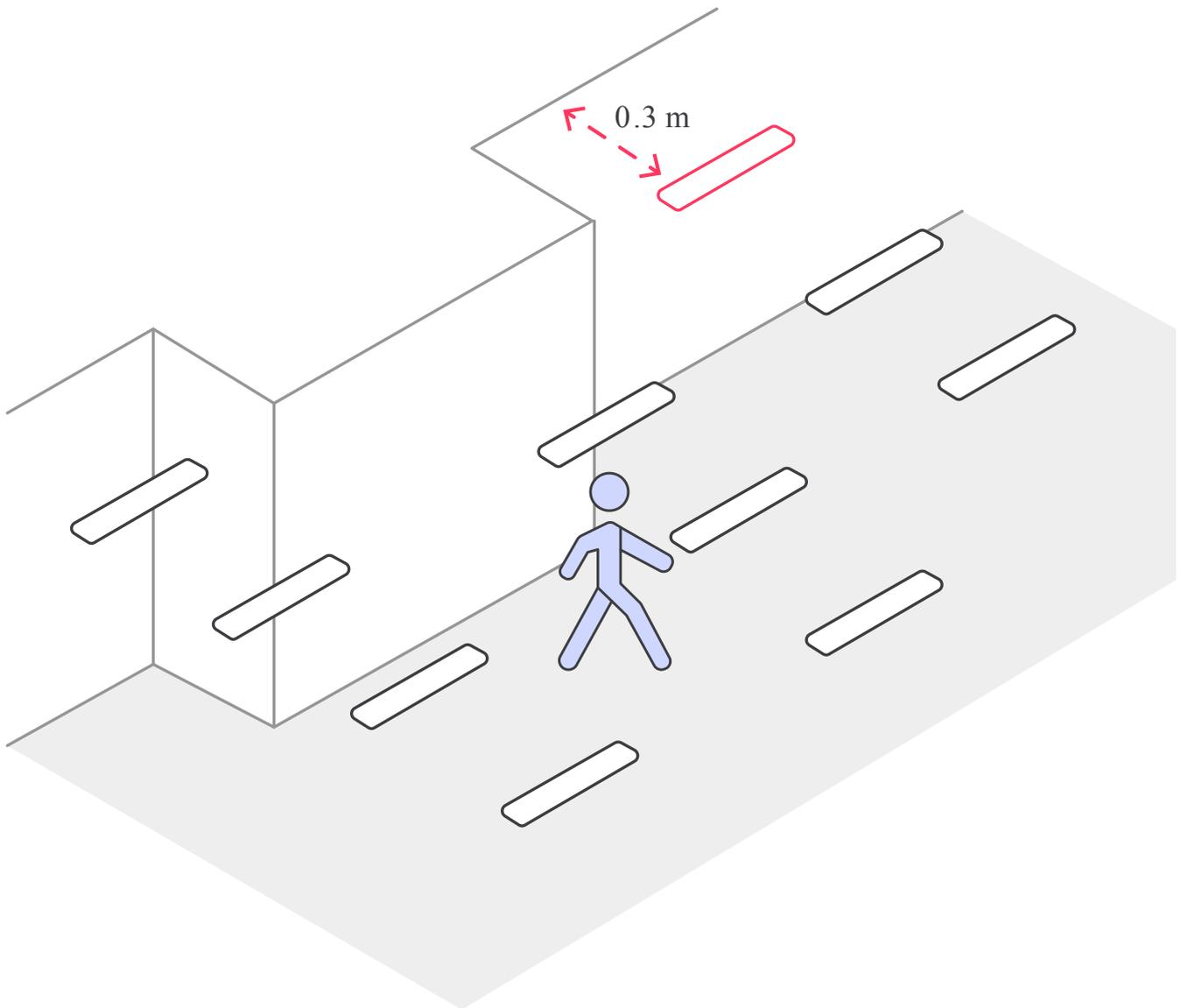

### 1.1.1. Blocking objects

The following recommendations are made regarding blocking objects:

#### ***Uneven ceilings***

If the blocking object is between two groups and there is a different communication path to the Wireless Gateway(s), then the luminaires can be installed.

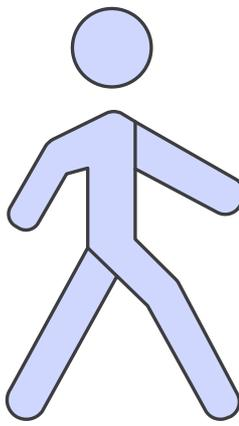
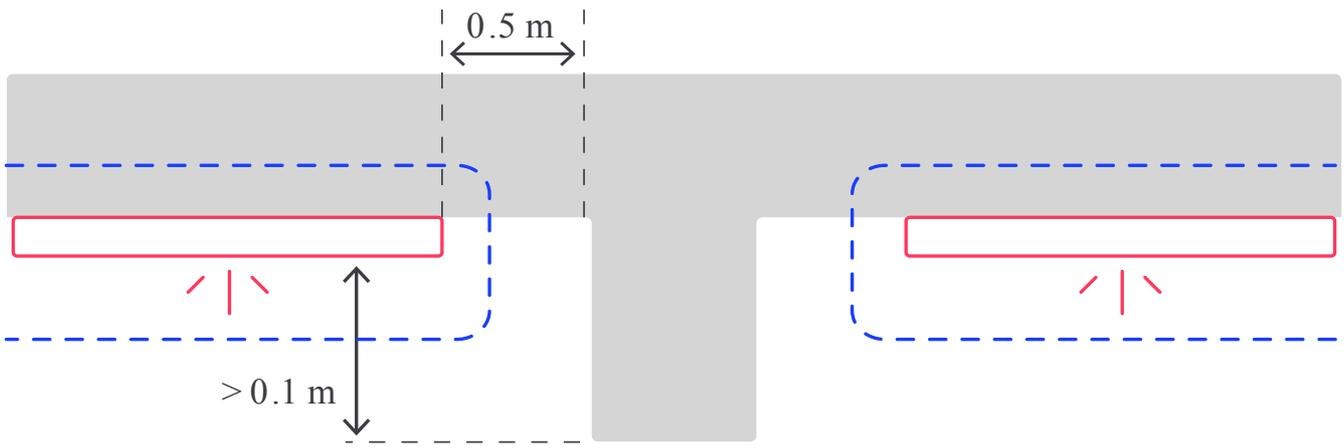

**Warning**

Do not install the luminaires close to concrete or metal constructions

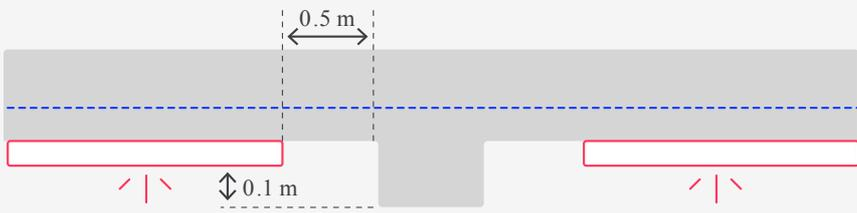

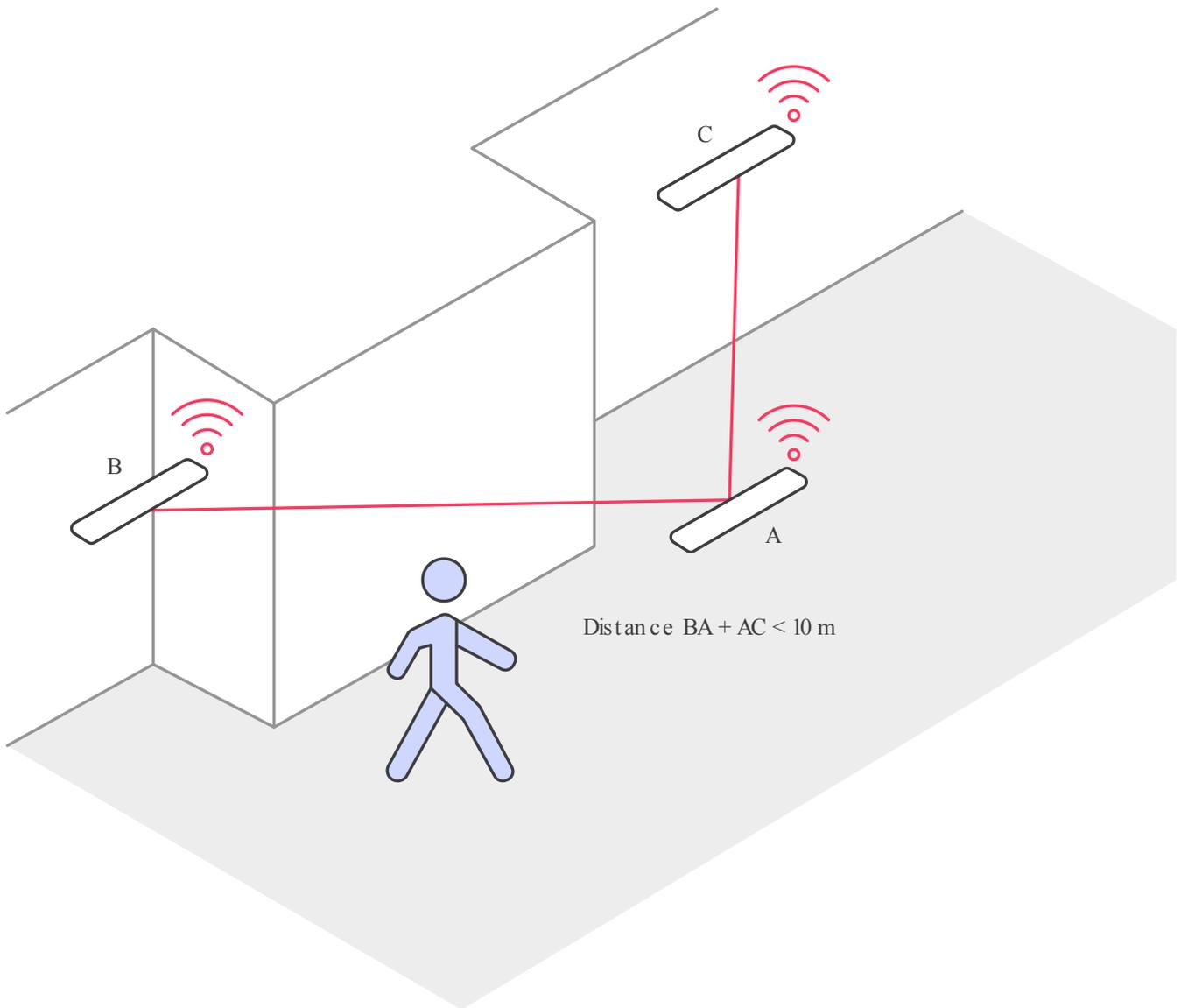

**Concrete construction wall**

Lights B and C can communicate with each other if the distance between B - A and C - A is less than 10 m (32.8 ft) and there is no blockage present.

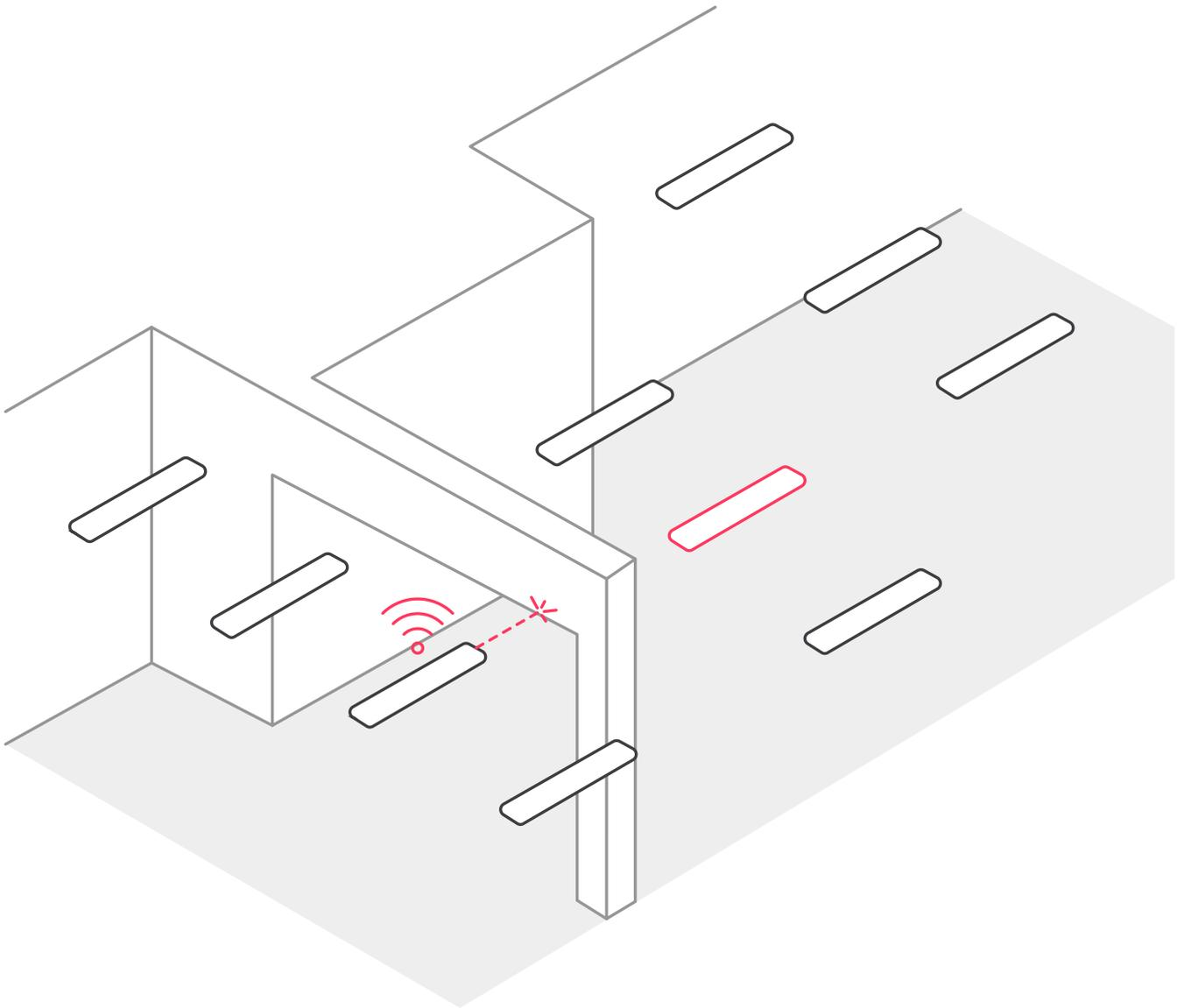

***Concrete construction ceiling***

A concrete beam can block the communication of the luminaire.

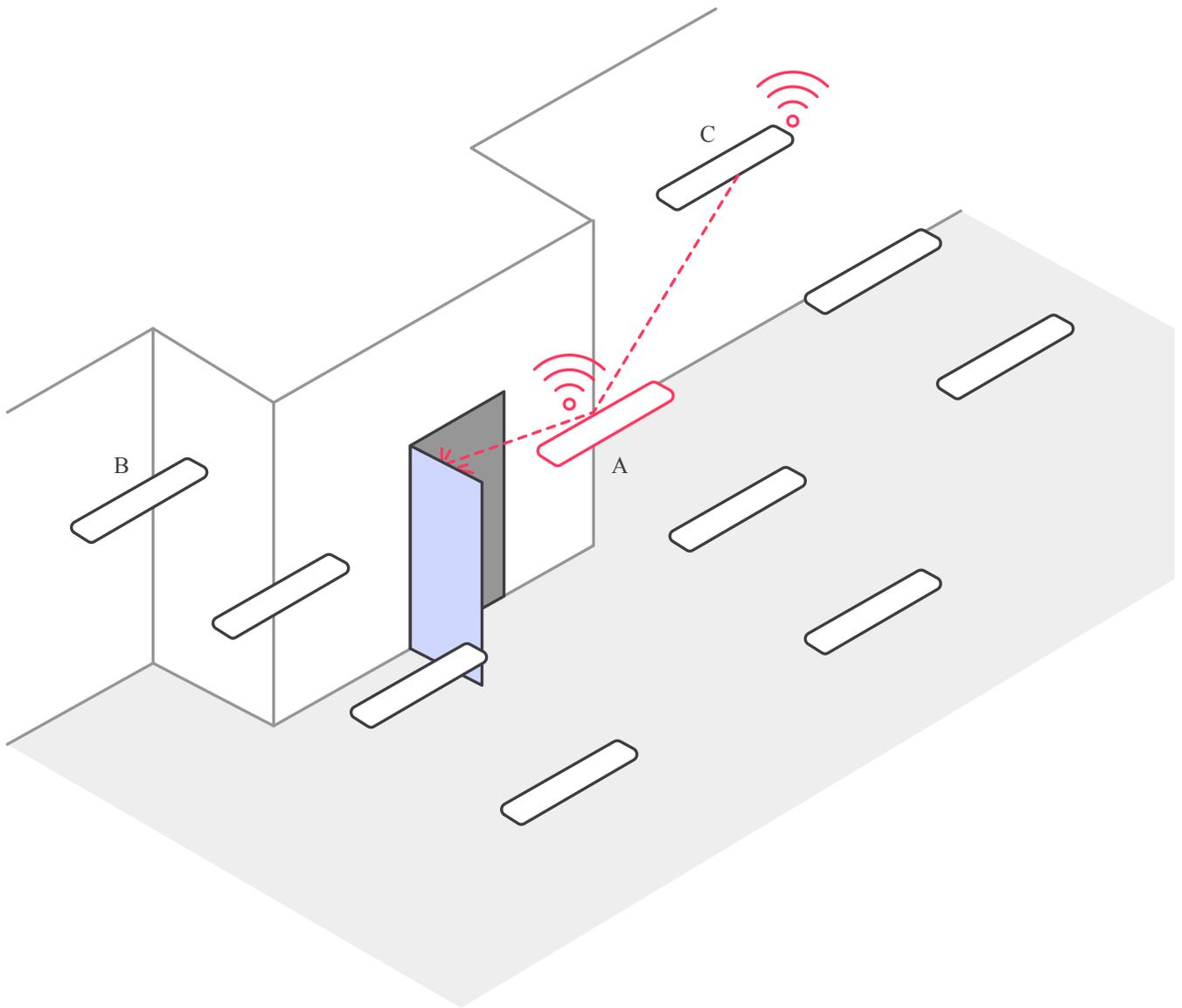

***Metal door***

A metal door can block the communication of the luminaire.

### 1.1.2. Map the traffic

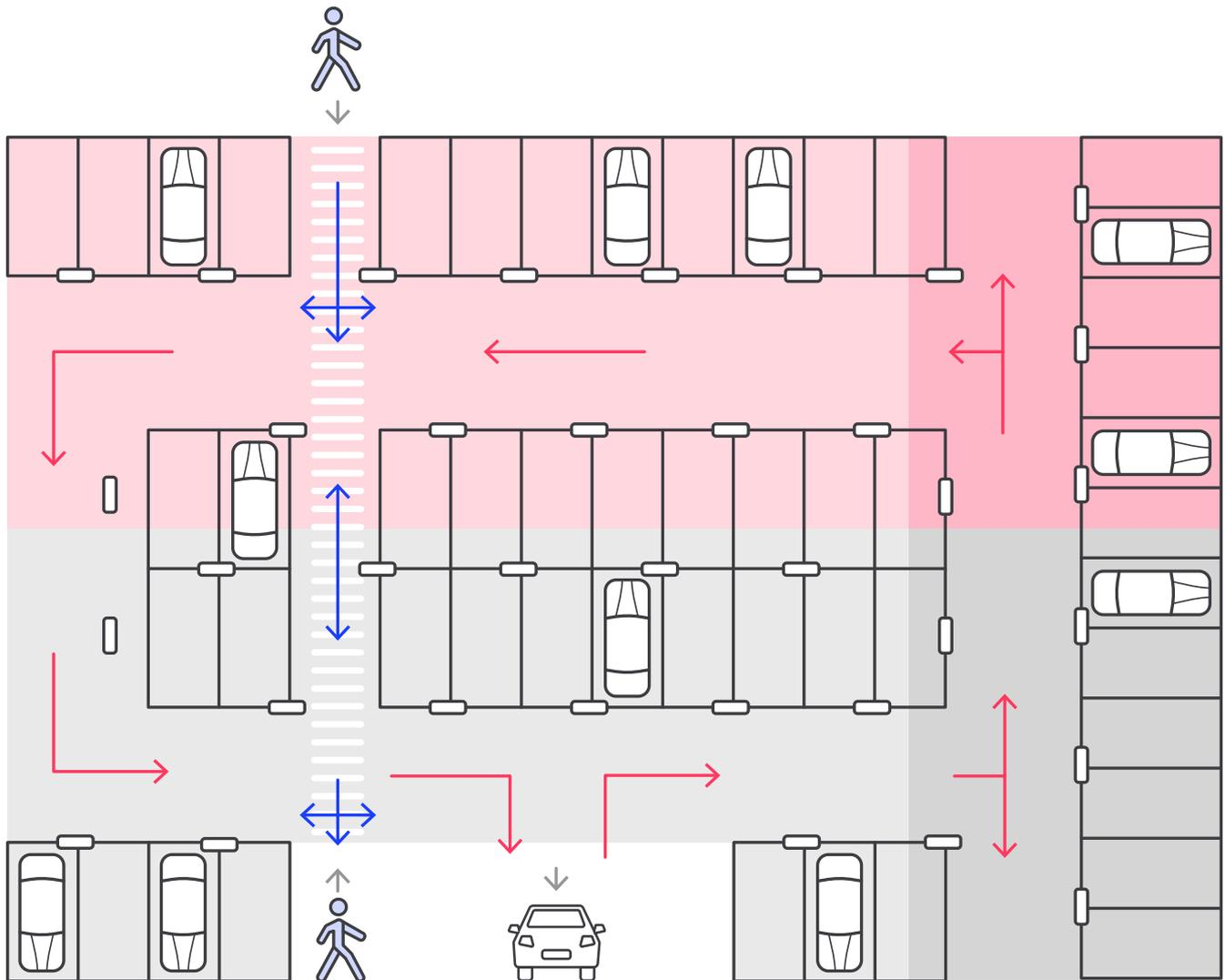

#### ***For people walking:***

- Start by mapping the formal routes people use
- include alternative routes that are frequently used

#### ***For cars:***

- Start by mapping the formal routes cars use

### 1.1.3. Define the lighting groups

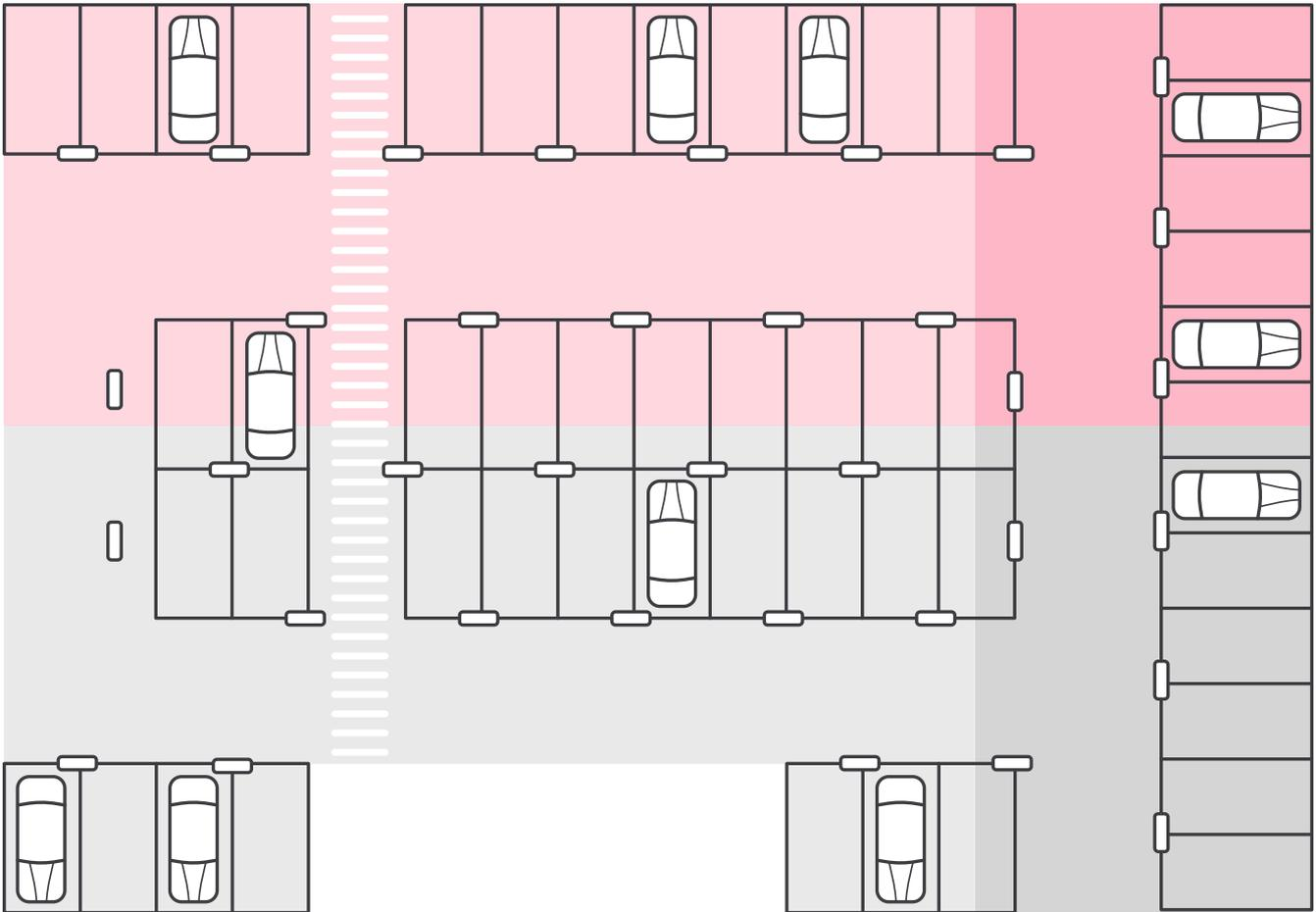

- At the entry of a lighting group sufficiently illuminate all directions (> 10 m).
- Lighting groups follow the official routes in the garage, priority on cars.
- Lighting groups follow logical interior shapes, such as isles, walls, etc.
- group length can be between 20 m (65.6 ft) and 40 m (131 ft) length.
- Lighting group width should include the aisle and bordering parking spaces.

### 1.1.4. Define the sensor plan for each group

Project the routings on the groups. For each group identify the points of entry for cars and people.

There are different spaces on a parking garage depending on the intended use:

- routing corridors for cars
- parking spots
- routing of people including entrance and exit routes

Smaller groups can provide higher energy savings, while larger groups can provide the conform of light.

Determine the group size based on the environmental conditions and customer preference.

Place battery-powered motion sensors

Place a sensor at each point of entry for people:

- when entering the car park at the edge of the group
- the detection group should overlap the adjacent group by 1-3 m

Place a sensor at each point of entry for cars:

- the detection group should overlap the adjacent group by 2-5 m

Optimizing sensors for cars

In case cars approach an group from more than one direction, different strategies can be applied:

1. Place a sensor right at the entrance of the lighting group

- late response to presence
- low coverage

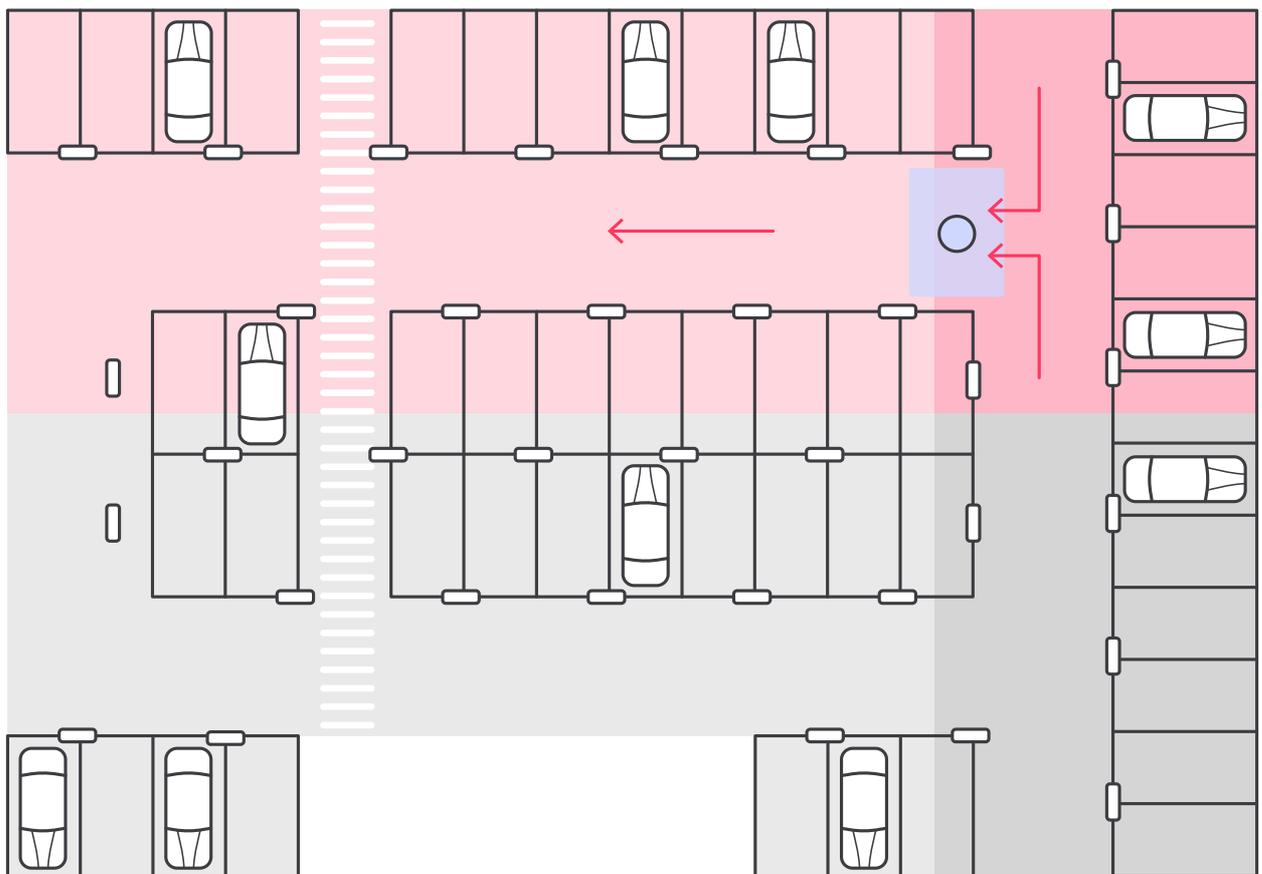

2. Place sensors at each route

- in time response

- more costly
- good coverage

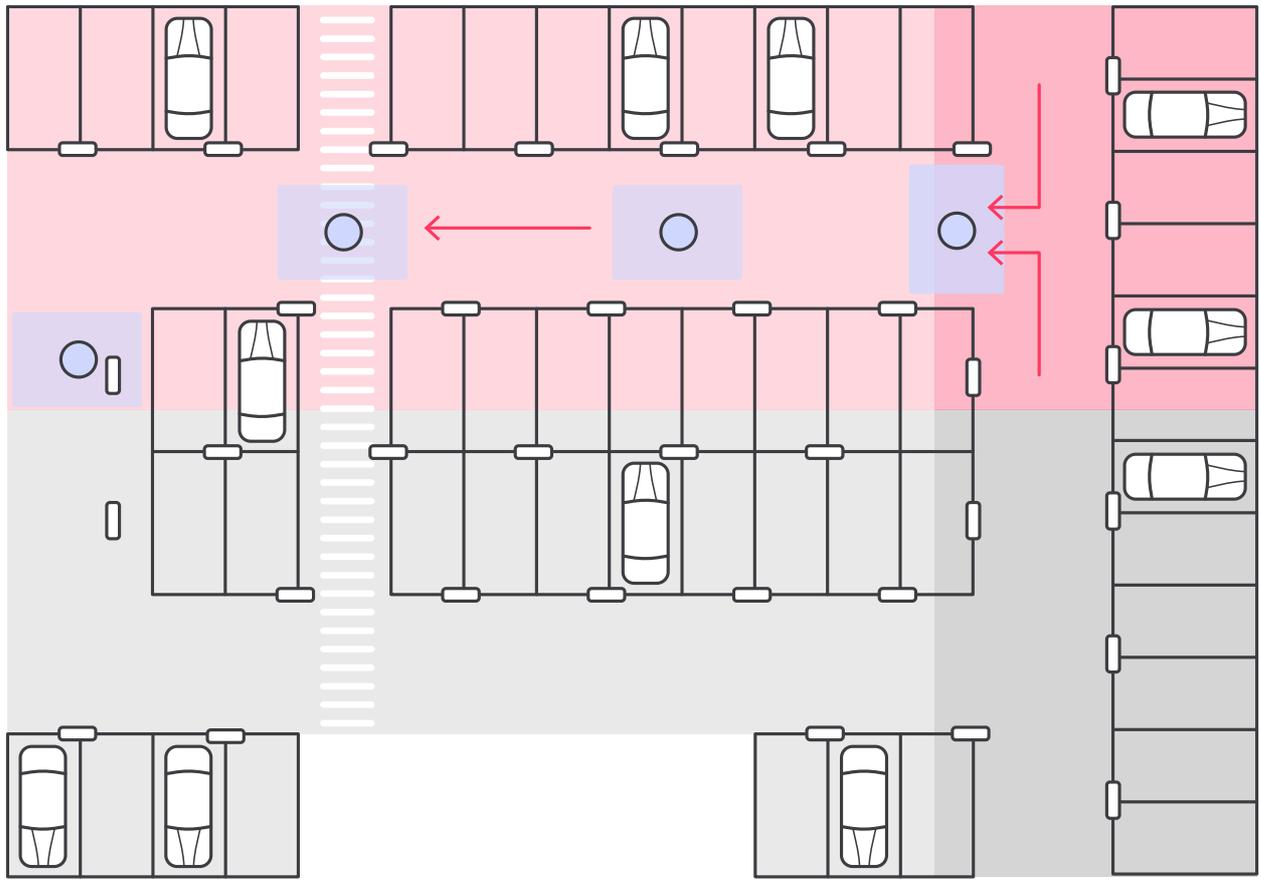

**Optimizing sensors for people**

Place sensors above each route as shown below:

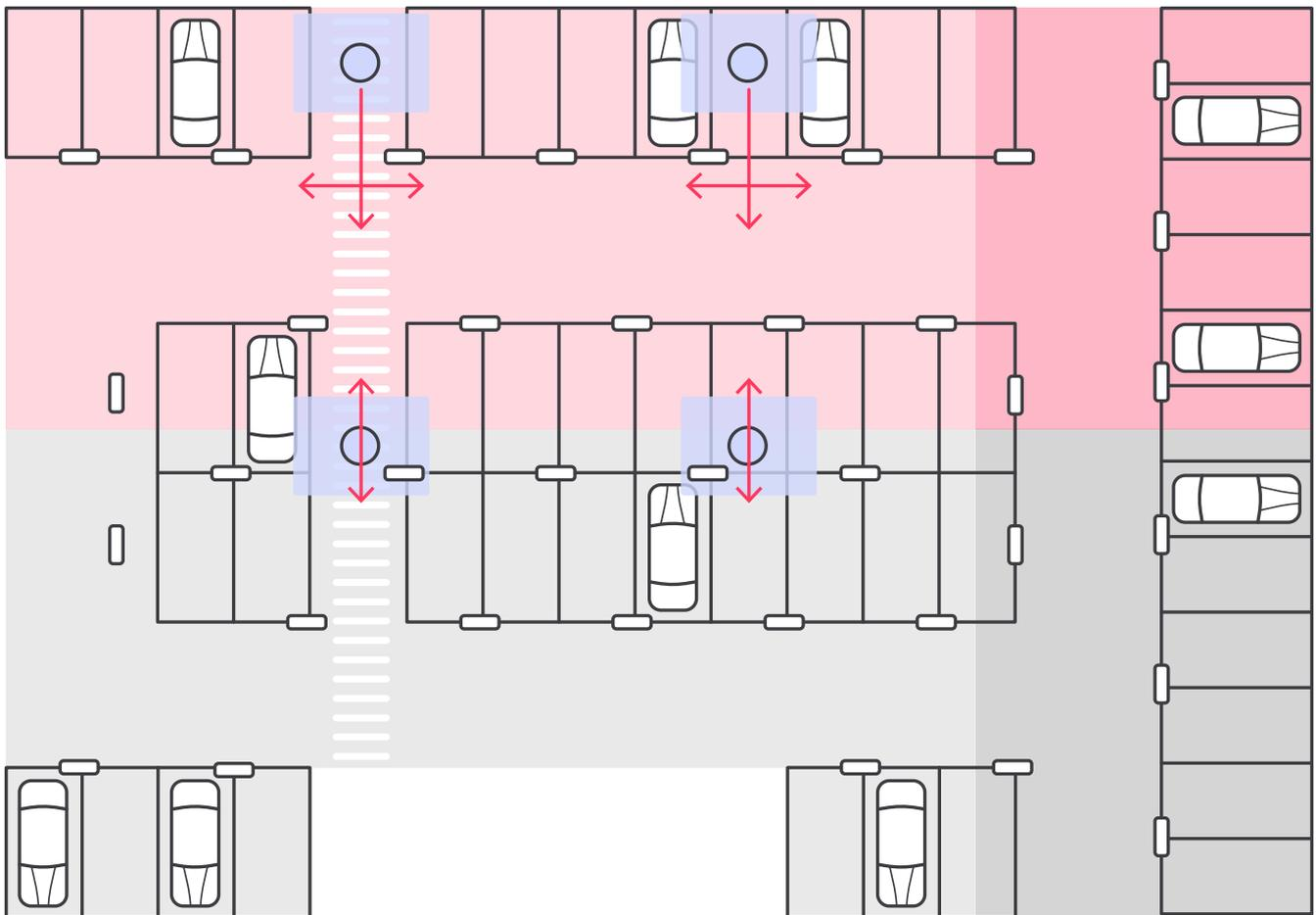

### Note



In case an group can only be entered from one direction, the light can dim before people have left the group. This can be prevented by placing supporting sensors.

## 1.1.5. Daylight harvesting

When daylight harvesting is used, place the sensors as instructed in the specification sheet. See more:

- Daylight harvesting for PRF/PRA

### Note



Only one daylight harvesting ZGP sensor can be used for per group. Choose the best position for this sensor which represents a good average for the full group.

## Field of view daylight

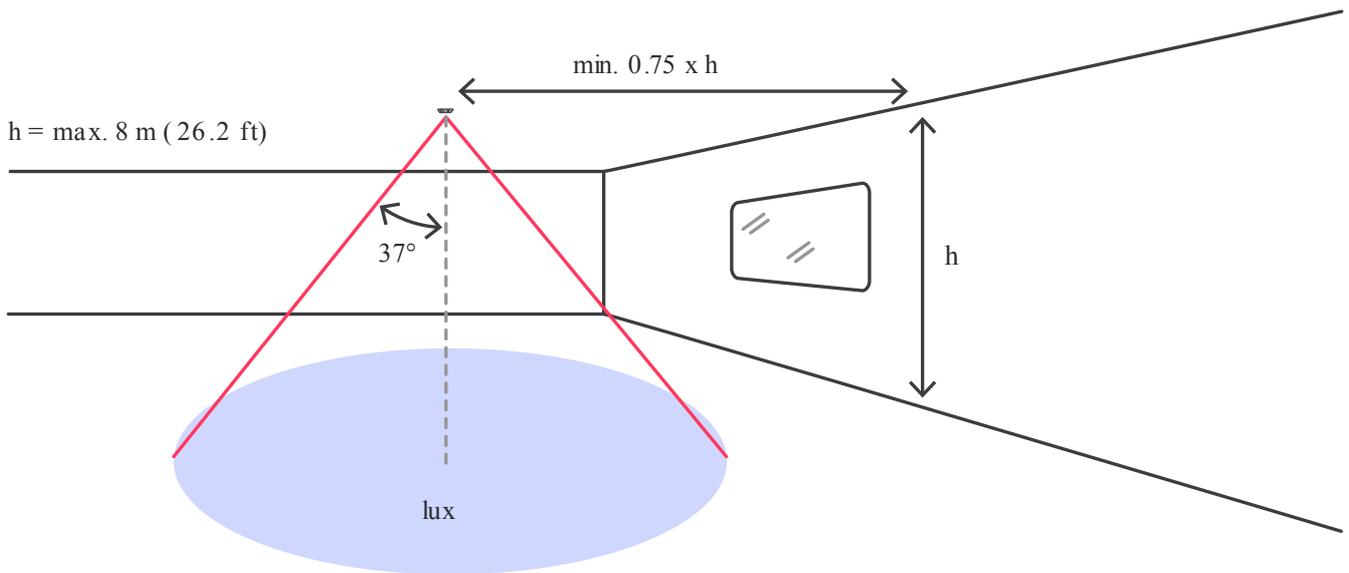

## 1.2. Guidelines for external battery powered motion sensor

### 1.2.1. Secure contact between sensors and luminaires

The following practices must be applied to secure contact between sensors and luminaires:

- Every sensor must be capable of establishing a connection with at least two luminaires
- Every luminaire must be capable of establishing a connection with at least two other luminaires

By implementing the above practices, the sensor can relay data to an alternative luminaire when it is unable to contact one.



#### Note

Depending on the size and nature of present obstacles, each location must be individually verified.

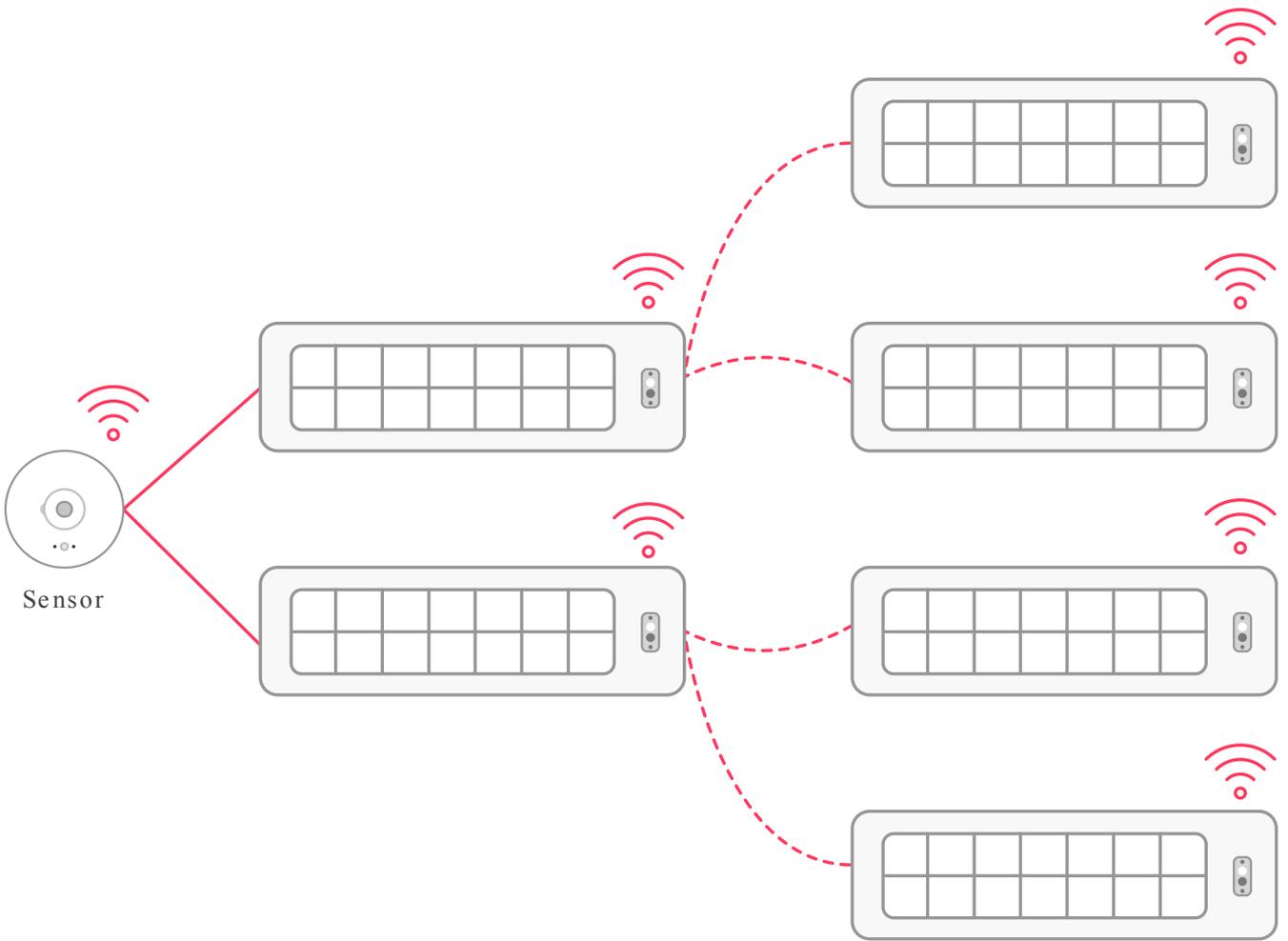

## 1.2.2. Position motion sensors

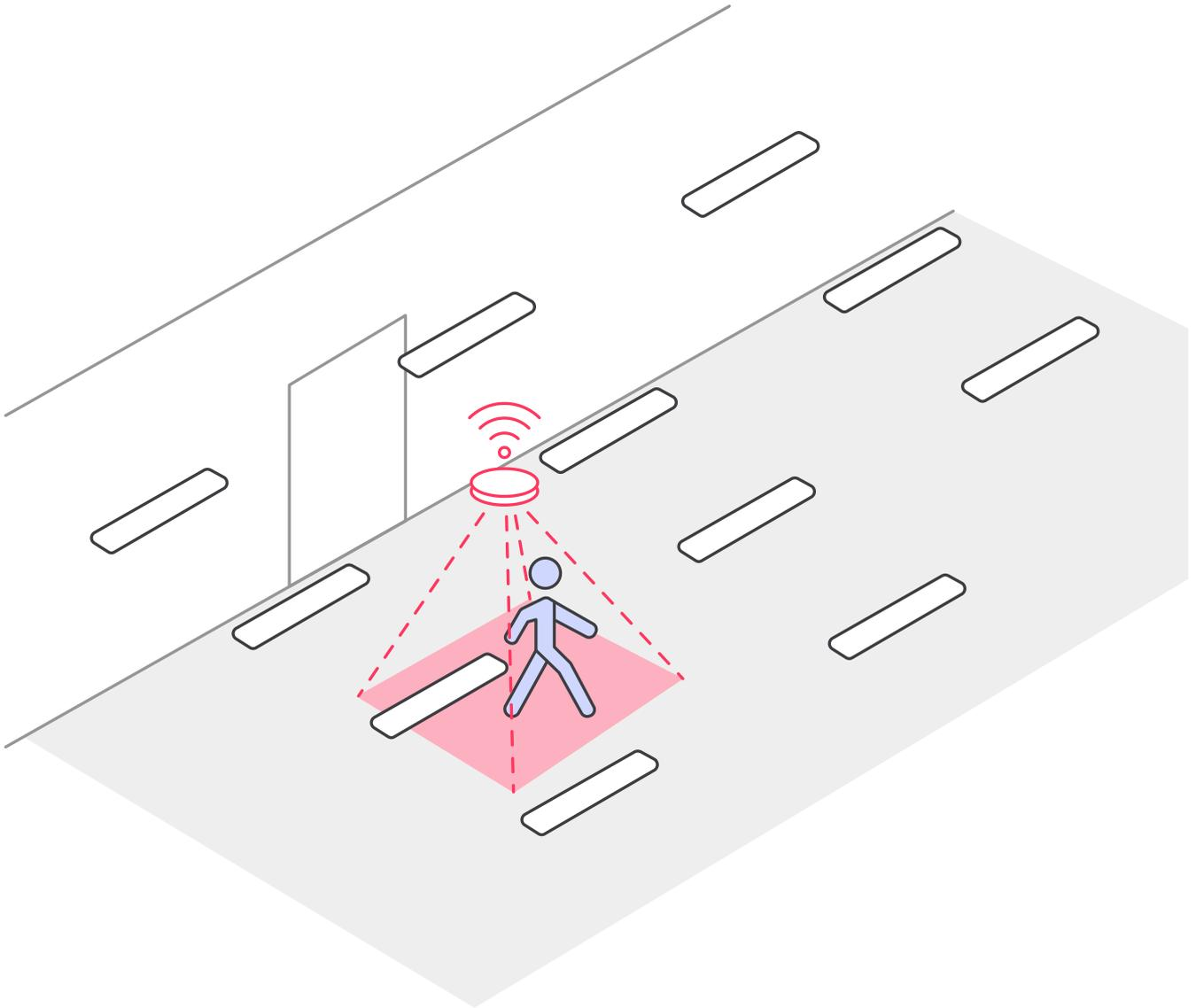

Add a ceiling sensor at every entrance/exit route, both for people and cars.



# Field- of-V view

Field of view motion

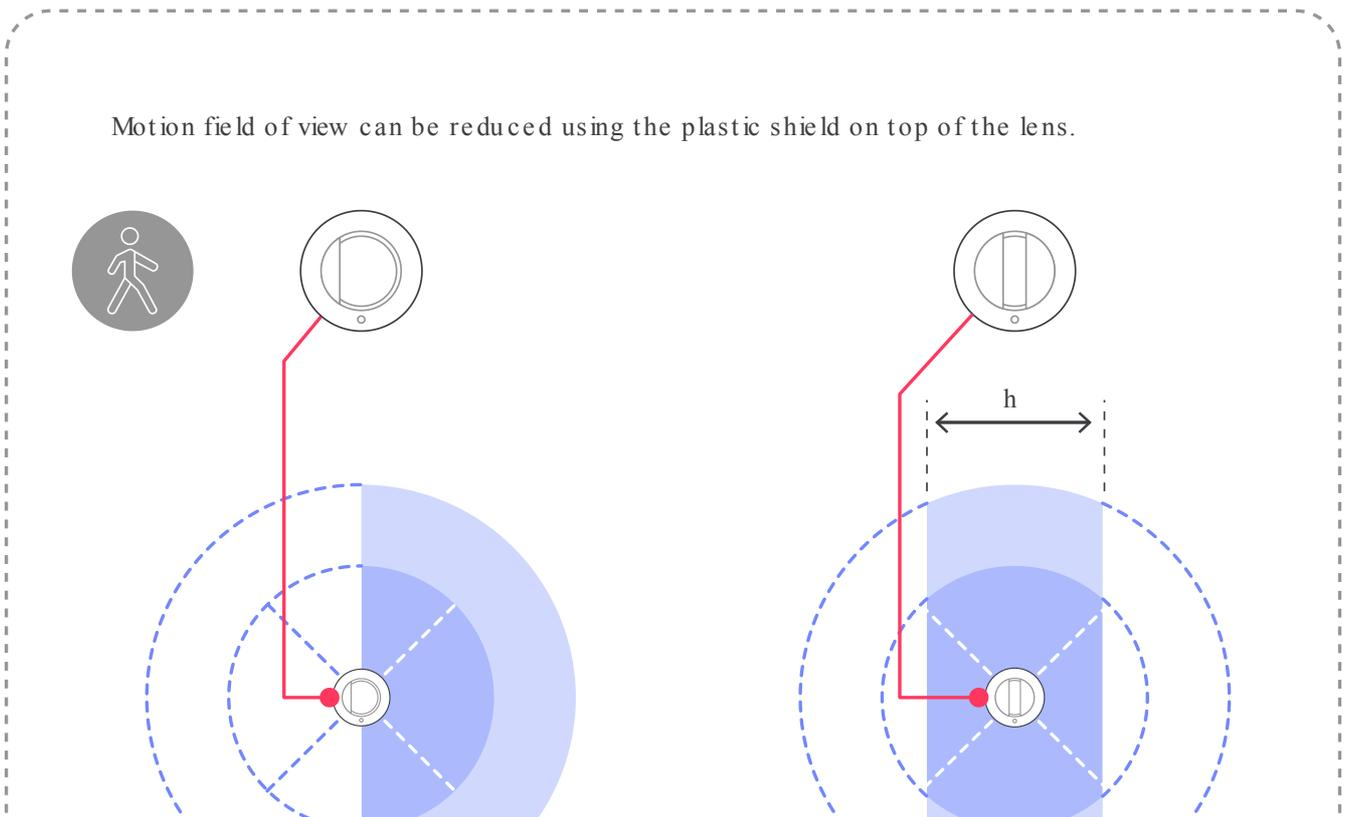
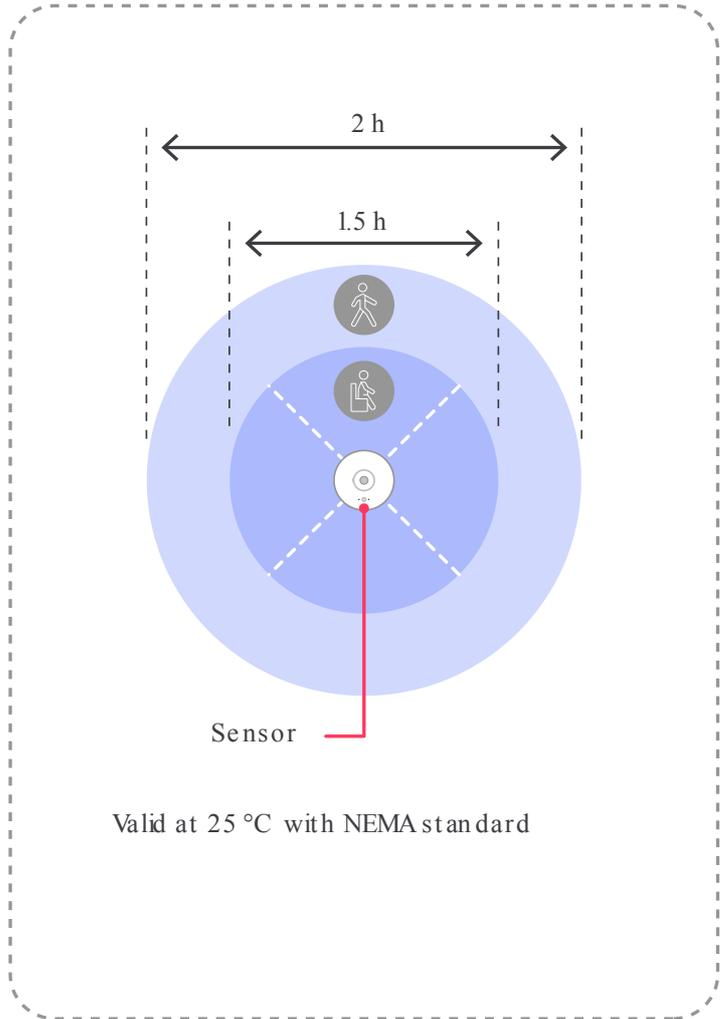
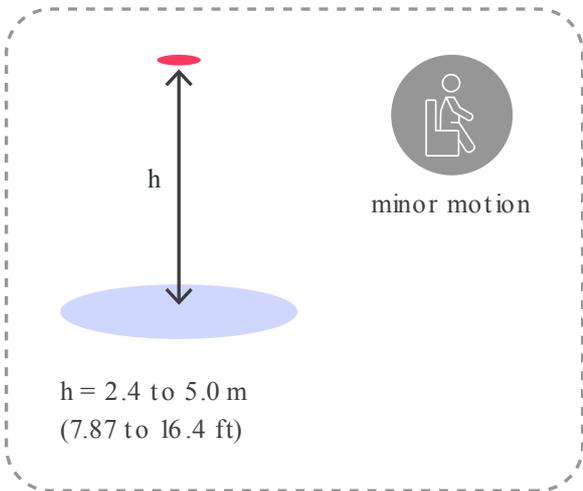
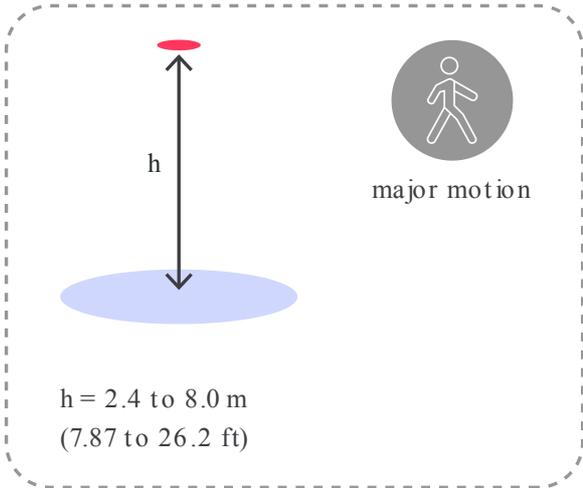

## Sensor detection group

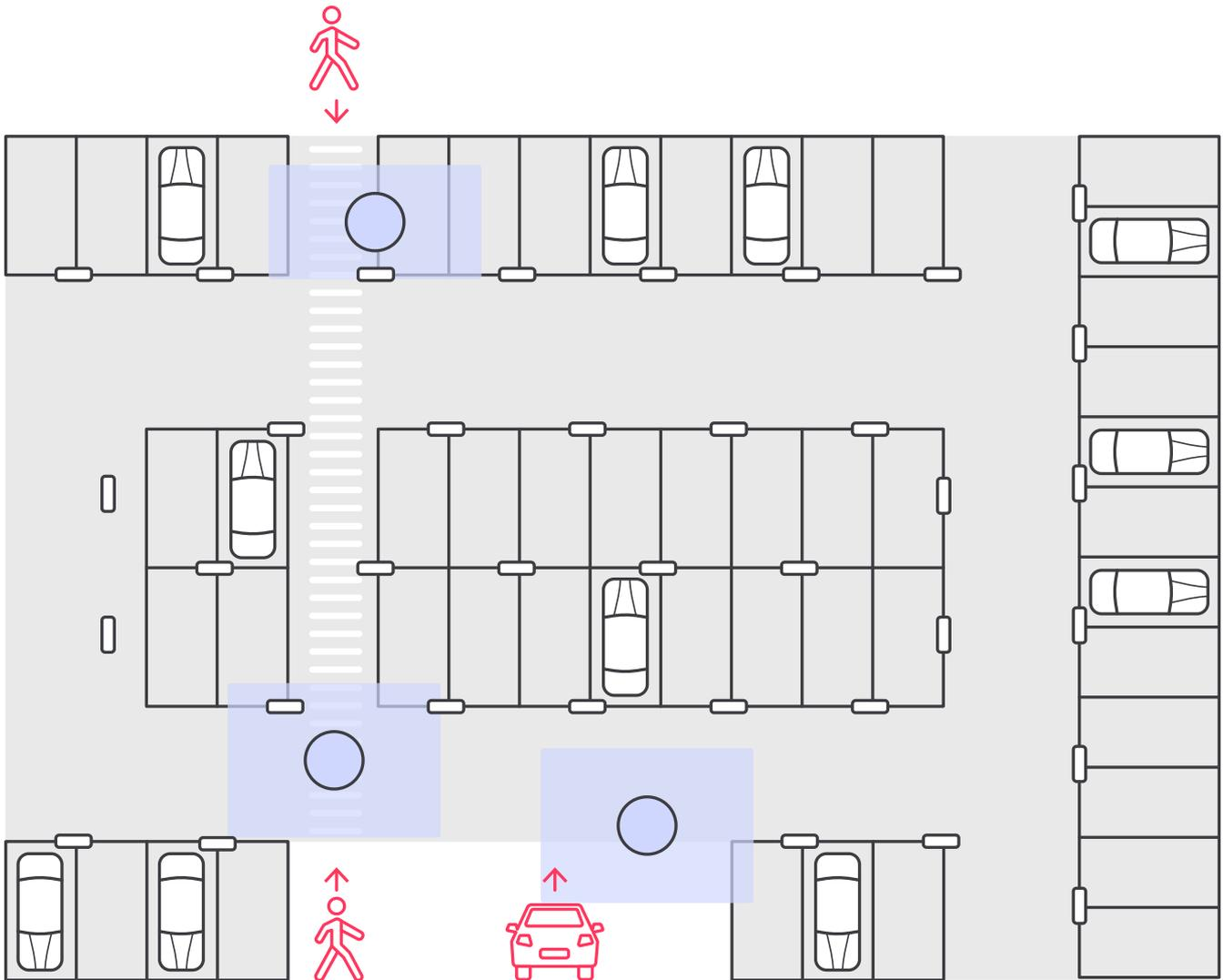

For example, ceiling sensors are installed at the entrance of the parking lot. The luminaires connected to it, switch on to task level as soon as the sensor detects a car or pedestrian entering the field of view. Now the driver or pedestrian has a clear view ahead.

### 1.2.3. General rules for external battery-powered sensors



#### Warning

ZGP battery-powered sensors do not report the battery level or when it is depleted. It is only possible to check if the sensor fails by verifying the LED indicators on the device.



#### Important

Replace the ZGP sensor's battery before the end of life.

- Place the sensors at the entrances of the parking lot and groups, based on the defined routes for cars and pedestrians.

- Place supporting sensors only when needed, such as large zones with only one entry or exit point
- It is not required to cover the complete group with sensors
- Take into account that cars and objects can block the sensor's field of view
- Install the sensors away from sources of heat

See more information about PRF/PRA sensors

## 1.3. System configuration

## 1.4. Light behavior

See more information about light behavior and parameters:

- PRF/PRA light behavior



### Note

The recommended template to be used is Auto On Auto Off.

### 1.4.1. Light behavior parameters for parking projects

#### Hold Time

The hold time configuration is a balance between visual comfort and energy savings, when increasing the hold time, it is less possible an group will turn off while there is someone still on the space, but this will result in the lights being turned On for longer periods of time, this balance can also be affected by the density of sensors designed, with a higher density of sensors a lower hold time can be used. For ZGP sensors the minimum supported hold time is 5 minutes, this is good enough for most situations, but when designing for a low density of sensors make sure the hold time is increased to 10 or 15 minutes.

#### Vacant level

For special situations where visual comfort is important, vacant level can be configured to a low dim level, for example 20%, this will prevent the lights turning off even when there is no presence, it can be combined with schedules to set it back to 0% when off working hours.

#### Others

Parameters like task level is usually set to 100% unless a lower light level is required than the one installed, the background level and prolong time are optional, but usually not commonly used for parking applications.

## 2. Design a trunking project

The purpose of this document is to explain different trunking options and which devices/architectures to choose depending on benefits and limitations. Introduction

Trunking covers any architecture where more than one driver is connected to a single wireless node, for example a sensor SNH210, SNS210, SC1500 or an antenna like the SNS441. Independently from the solution selected, when connecting multiple drivers to a single wireless node, all drivers always switch ON/OFF and dim together, it is not currently supported to address each one independently.

The following devices can be used for trunking applications and are compared against each other with benefits and limitations, also what is the recommended choice:

- DALI extender
- SR Bridge DALI
- SR Bridge 0-10V

## 3. Types of DALI Luminaires

First it is important to understand what type of DALI driver is in the luminaire, these can be identified by the icon printed on the driver or the datasheet, for the purpose of trunking applications we can have the following 4 varieties:

### 3.1. DALI Version 1



DALI 1 or commonly known as just DALI refers to an older version of the DALI protocol which only included control gear, it is not possible anymore to certify new products for DALI 1, for the purpose of this guide it is relevant to know that a DALI 1 driver does not provide a standardized way to report energy metering, it also does not provide power over DALI to energize a sensor.

### 3.2. DALI version 2



DALI-2 brings the promise of significantly improved interoperability and additional functionality compared with current DALI version-1 devices. Specifically, part 251, 252 and 253 guarantees that the driver to be compatible with our sensors and devices. DALI 2 drivers enable the possibility to directly read energy consumption, failures and device type (digital service Tag) from standardized memory locations. Over time it can also be extended into our systems with many more datapoints which are already supported by the driver like undervoltage detection, driver temperature, power cycles, etc...

### 3.3. DALI 2 + D4i



D4i is an extension of the DALI-2 certification program. D4i LED drivers have a mandatory set of features related to power-supply requirements and smart-data capabilities. Like an SR driver, our sensors are designed to work together with D4i DALI drivers and be energized by the driver.

### 3.4. SR Drivers



SR (Sensor Ready) drivers, use a standardized DALI interface plus an integrated power supply to energize the sensor, it was developed by Signify before D4i was created as a standard, for the purpose of this guide SR Drivers and D4i drivers can be used interchangeably.

### 3.5. Architecture options

### 3.6. Dali Extender (Recommended Choice if available)

The DALI extender can energize an SR sensor and transparently pass on DALI 2 commands to the drivers, it is optically isolated (SELV) which means that any electric issue on the driver side will not affect the sensor and vice versa. The advantage of the DALI extender is that it does not require any firmware to support new functionality, by updating the firmware of the sensor, it can easily support new improvements, fixes and features like tunable white and emergency remote testing.

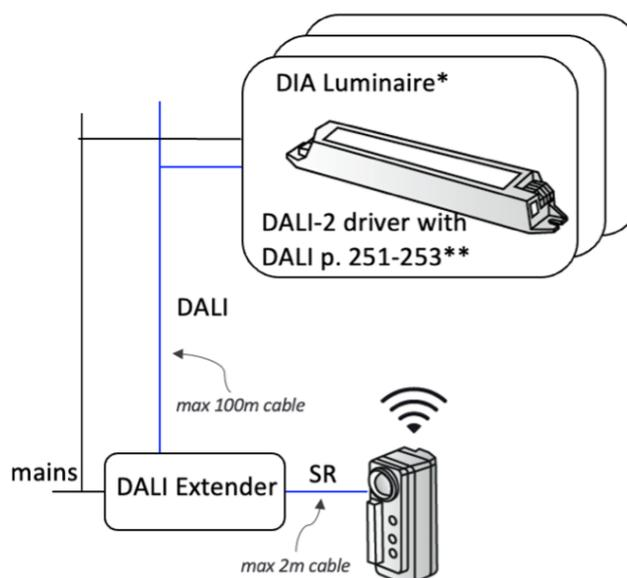

#### Benefits

Most cost-effective solution.

- Less wiring required, only DALI cabling is needed from the device to the luminaires.
- Transparent failure and energy reports from the drivers.
- Digital service tag supported (only one reported from a single driver at random)
- Maximum 20 drivers supported independently from luminaire power consumption.
- Future proof, no need for firmware updates as it is transparent for the sensors.
- Support for emergency driver with remote testing.
- Support for tunable white.
- CE certified.

#### ***Limitations***

- 220 to 240 V only, no support for 110 V.
- DALI version 1 not supported.
- Not UL certified.

### **3.7. SR Bridge DALI (Recommended choice only when DALI extender is not possible)**

The SR Bridge DALI needs a mains power connection, it energizes the SR sensor or antenna and translates the DALI messages from the sensor into the DALI port to the drivers, the mains power needs to go through the internal relay of the device to measure the energy consumption and fully switch off the power. A Multi-One interface can be used to configure the SR bridge, but the device cannot be firmware updated.

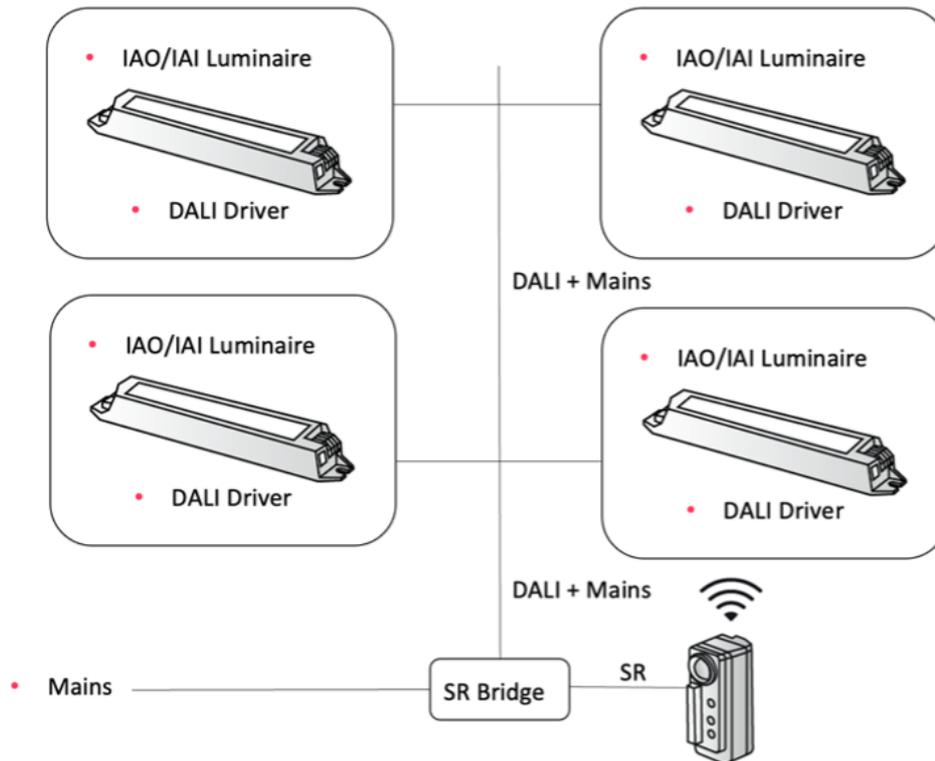

### Benefits

- Option to integrate DALI version 1 drivers.
- Configuration options available via Multi-One interface.

### Limitations

- Failure reporting has many known issues which may result into incorrect fault reports.
- Wiring requires both DALI and mains power to work properly.
- No support for emergency drivers with remote testing.
- Max 400 VA, for a trunking application using high power luminaires this could mean three to five luminaires only.
- Can not be firmware updated to fix or support new functionality.

## 3.8. SR Bridge 0-10V

The SR Bridge 0-10V needs a mains power connection, it energizes the SR sensor or antenna and translates the DALI messages from the sensor into the 0-10V port to the drivers, the mains power needs to go through the internal relay of the device to measure the energy consumption and fully switch off the power. A Multi-One interface can be used to configure the SR bridge, but the device cannot be firmware updated.

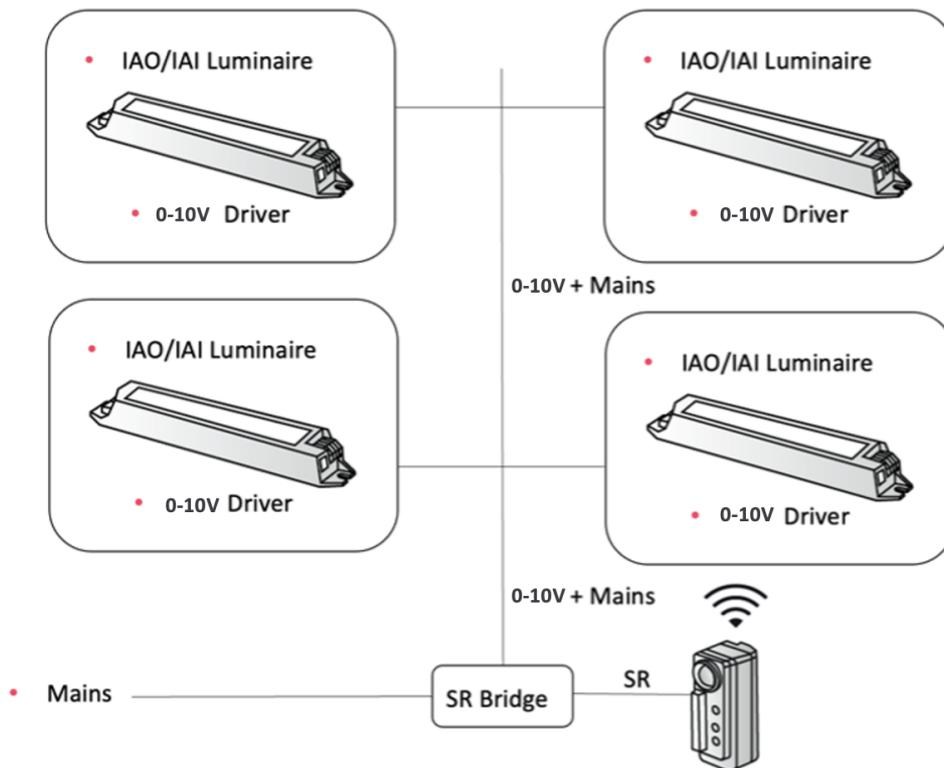

### Benefits

- Only option to integrate 0-10V drivers.
- Configuration options available via Multi-One interface.

### Limitations

- Failure reporting has many known issues which may result into incorrect fault reports.
- Wiring requires both 0-10V and mains power to work properly.
- No support for emergency drivers with remote testing.
- Max 6.1 A at 120 V, 6.1 A at 208 V, 5.3 A at 240 V, 4.6 A at 277 V, 3.7 A at 347 V.
- Cannot be firmware updated to fix or support new functionality.

## 3.9. SR drivers or D4i drivers directly connected to the SR sensor or antenna

Multiple SR and D4i drivers can be connected directly to the SR sensor, however a maximum of four active power supplies must be active at a single time, otherwise it can be physically damaging to the sensor. This architecture is possible in some situations where a maximum of four drivers are needed and those drivers have integrated power supplies, in that case there is no need for a DALI extender or SR Bridge.

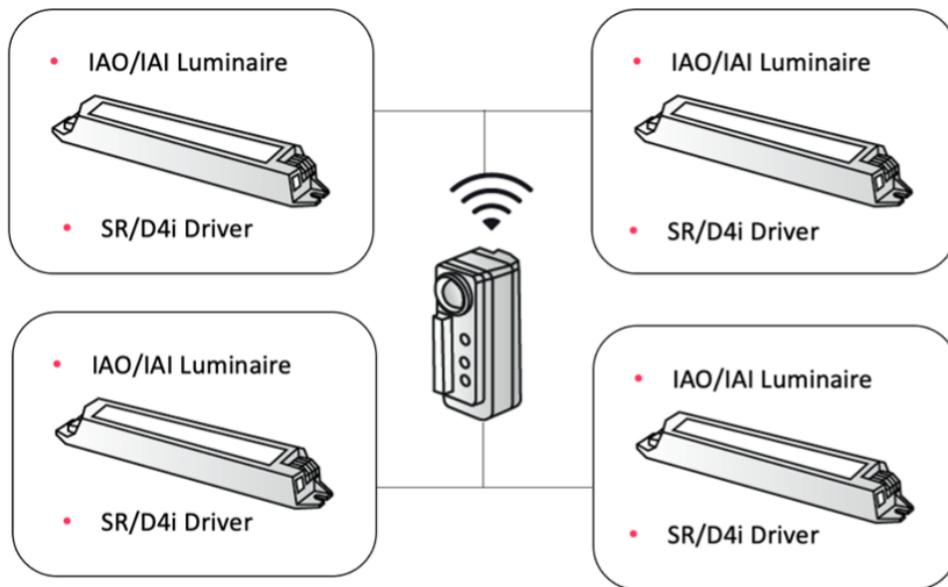

### **Benefits**

- Most cost-effective solution as no extra components are required.
- Less wiring required, only DALI cabling is needed from the sensor to the luminaires.
- Transparent failure and energy reporting from the drivers.
- Digital service tag supported (only one reported from a single driver at random).
- Future proof, no need for firmware updates as it is transparent for the sensors.
- Support for emergency driver with remote testing.
- Support for tunable white.

### **Limitations**

- DALI version 1 not supported.

## 3.10. Recommendation table for trunking applications

Type/Architecture	DALI Extender	SR Bridge DALI	SR Bridge 0-10V	Direct connection to SR
DALI 1	Not supported	Best choice	Not supported	Not supported
DALI 2	Best choice	Not supported	Not supported	Not supported
DALI 2 + D4i / SR	Best choice (if more than four drivers)	Not supported	Not supported	Best choice (if four or less drivers)
0-10V	Not supported	Not supported	Best choice	Not supported
ON/OFF	Not supported	Best choice	Best choice	Not supported

Learn more about Interact  
[www.interact-lighting.com](http://www.interact-lighting.com)

© 2024 Signify Holding. All rights reserved.  
Specifications are subject to change without notice. No representation or warranty as to the accuracy or completeness of the information included herein is given and any liability for any action in reliance thereon is disclaimed. All trademarks are owned by Signify Holding or their respective owners.