

PHILIPS

Wireless Gateway

LCN1870



Specification Sheet

LCN1870 Wireless Gateway

The Wireless Gateway (WG) is a wireless communication hub that connects Zigbee nodes (for example luminaires including a sensor or Zigbee Green Power sensors and switches) in a Connected Lighting system.

The Wireless Gateway is a multi-platform device which can be used in a variety of systems, each system can upgrade its software to match the system features. The Wireless Gateway translates between Ethernet and Zigbee. It provides a wireless networked lighting.

LCN1870

Product description

The Wireless Gateway is powered by a 5 V_{dc} Class 2/SELV power adapter.

Wireless communication complies with the Zigbee Pro standard (IEEE 802.15.4, WPAN) in the 2.4 GHz frequency band. The Wireless Gateway must be placed within 10 m (33 ft.) from one or more of the Zigbee luminaires to form a mesh network. Communication between Philips wireless devices and the Wireless Gateway is encrypted, as well as the communication between the Wireless Gateway and the devices on the cloud.

The Wireless Gateway establishes a secure wireless Zigbee connection with the end points. The wireless connections **allow** for bidirectional control and sensor metrics data exchange between the end points and the connected system.

Dimensions

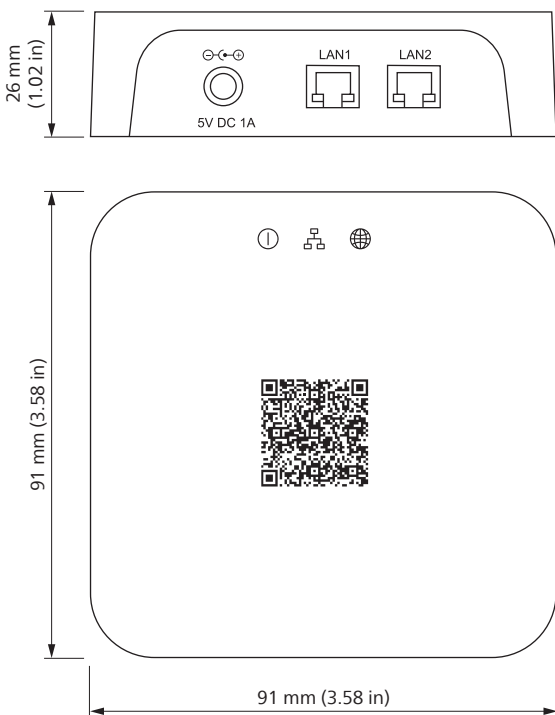

Features and benefits

- White enclosure and mounting bracket.
- 3 LED indicators for feedback on power, connectivity, and communication.
- It has a unique QR code for installation and commissioning.
- Supports secure encrypted communication to the cloud.
- Controls associated end points without access to the cloud (lighting behavior).
- Lighting behavior of end devices remains operational upon failure.
- Remotely manageable, upgradeable, and controllable.
- Secure wireless communication based on the Zigbee PRO standard (IEEE 802.15.4, WPAN) operating at 2.4 GHz radio frequency (RF).
- Easily scale up the system by connecting multiple Wireless Gateways over Ethernet.
- Functions for the Wireless Gateway and all connected devices can be modified with software configurable settings.

Wireless communication

The Wireless network is based on the Zigbee PRO standard (IEEE 802.15.4, WPAN) which is targeted at radio-frequency (RF) applications and operates at 2.4 GHz. The Zigbee protocol enables fully distributed peer-to-peer communication models. This means no master/ slave relationship whereby the application is divided over the devices in the network. Every device knows how it functions within the network. The result is that if one device does not function (removed or defect), the remaining devices keep functioning as intended.

The network is based on a mesh network, so devices pass on the received commands. The distance between the devices must not exceed 10 m (33 ft) for office applications and 15 m (49 ft) for industry applications. The advantage of a mesh network is the capability for self-healing routing, enabling automatic route discovery over the mesh network. Zigbee has tolerance for a large number of co-located networks due to use of multiple communication channels and CSMA-CA channel access. The commands have network security according to AES 128-bits network encryption. Other connected lighting wireless devices like the kinetically-powered Zigbee Green Power (ZGP) Switches use of the same protocol so they can be combined to interact in a seamless way.

The Wireless Gateway supports encrypted and secure wireless network communication. Third-party Zigbee devices can only join the Zigbee network if their unique identifiers are explicitly enabled in the system.

Note
Wireless signals may be subject to radio frequency interference.

Electrical diagram

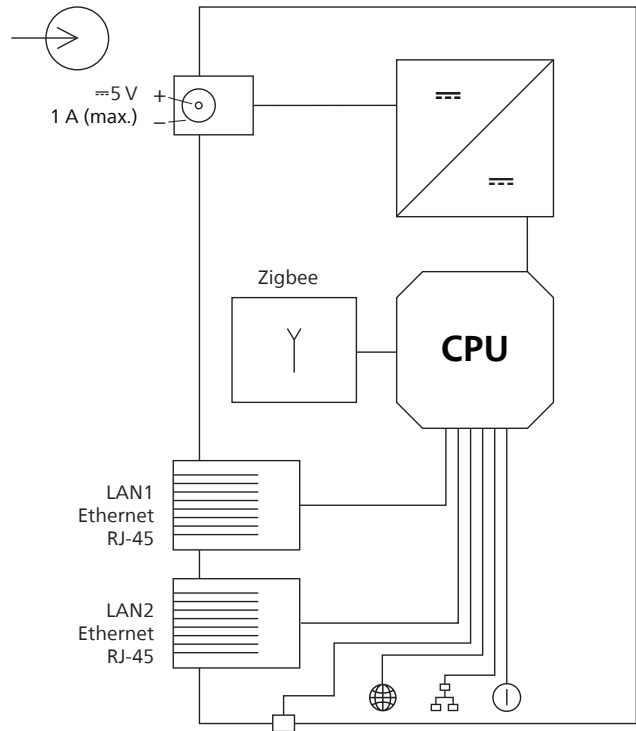

Specifications

General Characteristics

Supply options

Commercial grade regulated power supply	In: 100 to 240 V _{ac} , 50/60 Hz Out: 5 V _{dc} Class 2/SELV; 1 A
Allowed supply ripple	Max. 0.5 V _{pp}
Power consumption	Max. 2.5 W
Communication ports	2x 10/100BaseT Ethernet port Zigbee port
Supported Ethernet protocols	IPv4, IPv6, TCP, UDP, BACnet-IP

Environmental conditions operating

Ambient temperature range	-20 to +45 °C (-4 to +113 °F)
Relative humidity range	0 to 80%, non-condensing

Environmental conditions storage

Temperature range	-40 to +80 °C (-40 to +176 °F)
Relative humidity range	0 to 90%, non-condensing

Connector type

Supply in	One DC plug 5.5 mm (0.2 in) ⊖←⊕
Ethernet	RJ-45
Wireless Communication	Zigbee PRO standard (IEEE 802.15.4, WPAN)

Housing

Material	ABS
Color	Signal white (RAL9003)
Dimensions (length, width, height)	91.0 x 91.0 x 26.0 mm (3.58 x 3.58 x 1.02 in)
Weight	0.095 kg (0.21 lb) (including mounting bracket)

Mounting bracket

Material	ABS
Color	Signal white (RAL9003)
Dimensions (length, width, height)	96.2 x 96.9 x 33.9 mm (3.79 x 3.81 x 1.33 in)
User Controls	Reset push button, Status LEDs (Power, Network, Portal)

Regulatory compliance

Certifications	CE, UKCA, UL, FCC, IC
----------------	-----------------------

Approbation Europe

R&TTE RF	ETSI EN 300 328 EN 62311
R&TTE EMC	ETSI EN 301 489-1/17 EN 55032 EN 61000-3-2 EN 61000-3-3

Approbation US and Canada

General radio equipment	FCC Part 15.247; 15.107; 15.109 IC RSS-247 ICES-003
Safety	EN 62368-1 (UL60950-1 and CAN/CSA-C22.2 No. 60950-1-07)
Immunity	IEC 61000-4-2, 3, 4, 5, 6, 8, 11
Reliability	IEC 60068
Environmental standard	ROHS/Reach



Packing Data

Type	Dimensions	Qty/Box	Material	Weight (net)	Weight (gross)
LCN1870	110 x 80 x 110 mm (4.3 x 3.1 x 4.3 in)	1	Cardboard	0.18 kg (0.40 lb)	0.31 kg (0.68 lb)

Ordering data

EU version

Type	MOQ	Ordering number	EAN code level 1	EAN code level 3	EOC
LCN1870 Wireless Gateway	1	9137 010 42103	8718699 704643	08718699704650	704643 00

US version

Type	MOQ	Ordering number	UPC code level 1	UPC code level 3	Catalog code
LCN1870 Wireless Gateway	1	9137 010 42113	046677559106	50046677559101	LCN1870/05

FCC/IC compliance statement

This device complies with part 15 of the FCC rules for the United States and Industry Canada (IC) license - exempt RSS standard(s). Operation is subject to the following two conditions: (1) This device may not cause harmful interference, and (2) this device must accept any interference received, including interference that may cause undesired operation. Any changes or modifications not expressly approved by Signify could void the authority of the user to operate this equipment. This product is intended for commercial use only.

FCC Compliance Statement

This device complies with part 15 of the FCC Rules. Operation is subject to the following two conditions: (1) This device may not cause harmful interference, and (2) this device must accept any interference received, including interference that may cause undesired operation.

IC Compliance Statement

This device complies with Industry Canada license-exempt RSSs. Operation is subject to the following two conditions: (1) This device may not cause interference, and (2) this device must accept any interference, including interference that may cause undesired operation of the device. Any changes or modifications not expressly approved by Signify could void the authority of the user to operate this equipment. This equipment is intended for commercial use only.

FCC Radiation Exposure Statement

This equipment complies with FCC radiation exposure limits set forth for an uncontrolled environment. This equipment must be installed and operated with minimum distance 0.2 m between the radiator and your body.

IC Radiation Exposure Statement

This equipment complies with IC RSS-102 radiation exposure limits set forth for an uncontrolled environment. This equipment must be installed and operated with minimum distance 0.2 m between the radiator and your body.

Open source statement

This product contains open source software. The acknowledgements, license texts and the written offer can be retrieved from the product after installation using a web browser by opening the following web page <https://interact.lighting.com/lightopensource/>. This link allows you to enter the mac address that can be found on the label at the back of the product. This web service will subsequently retrieve the acknowledgments, license texts and written offer from the device with that particular mac address, providing you with the information corresponding to the then current open source software in the device.

